

APPROVED: *[Signature]*  
 DATE: 10-11-94

Title <b>C-PLOT2 SCHEMATIC</b>		
Size A4	Number <b>TMQ-QS-CPLOT2-002</b>	Revision <b>2</b>
Date: 15-JUL 1994	Sheet 2 of 2	
File: CPLOT2/2	Drawn By: JD	

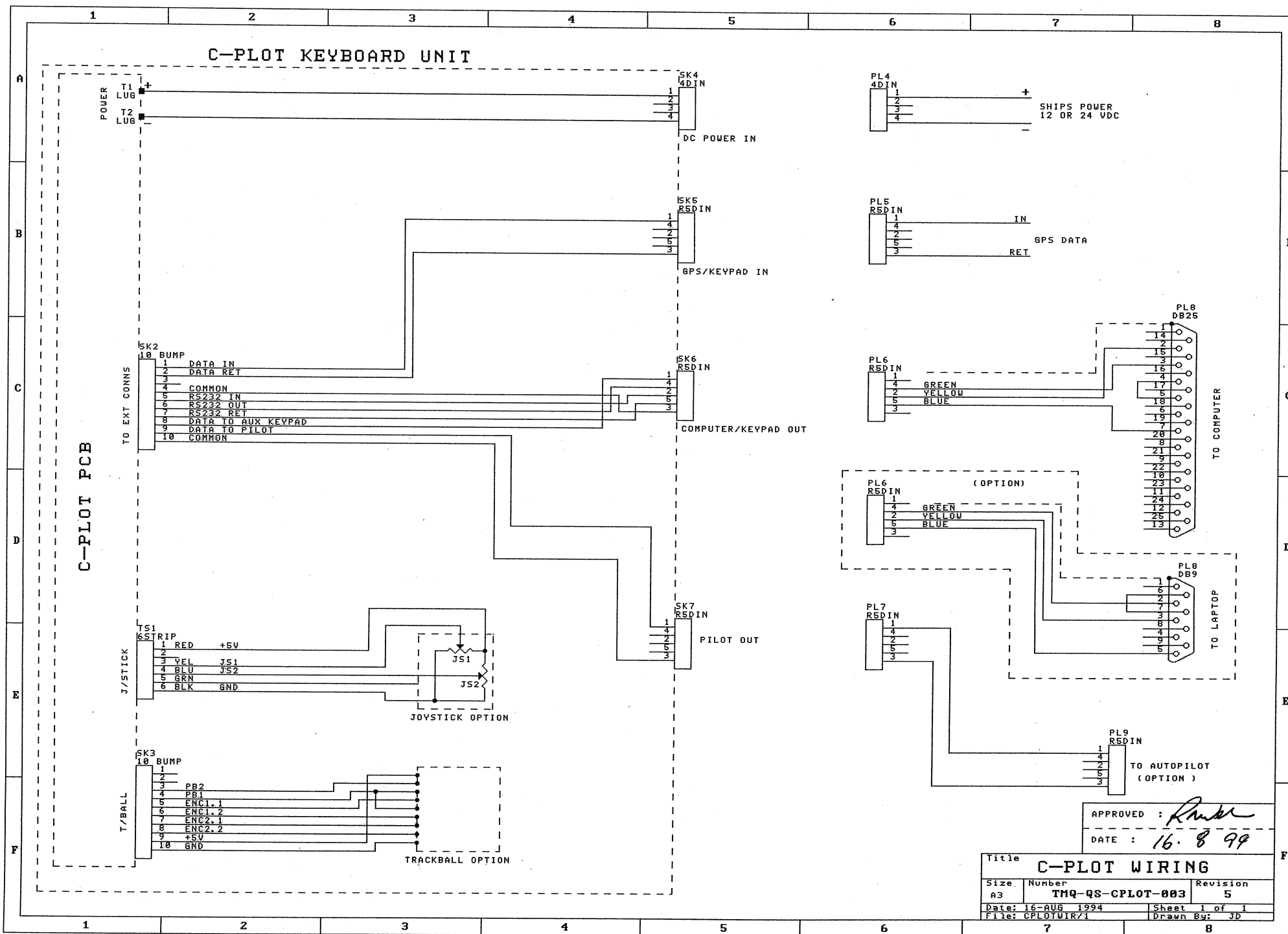

APPROVED : *[Signature]*  
 DATE : 16.8.99

Title <b>C-PLOT WIRING</b>		
Size A3	Number <b>TMQ-QS-CPLOT-003</b>	Revision 5
Date: 16-AUG 1994	Sheet 1 of 1	
File: CPLOTWIR/1	Drawn By: JD	

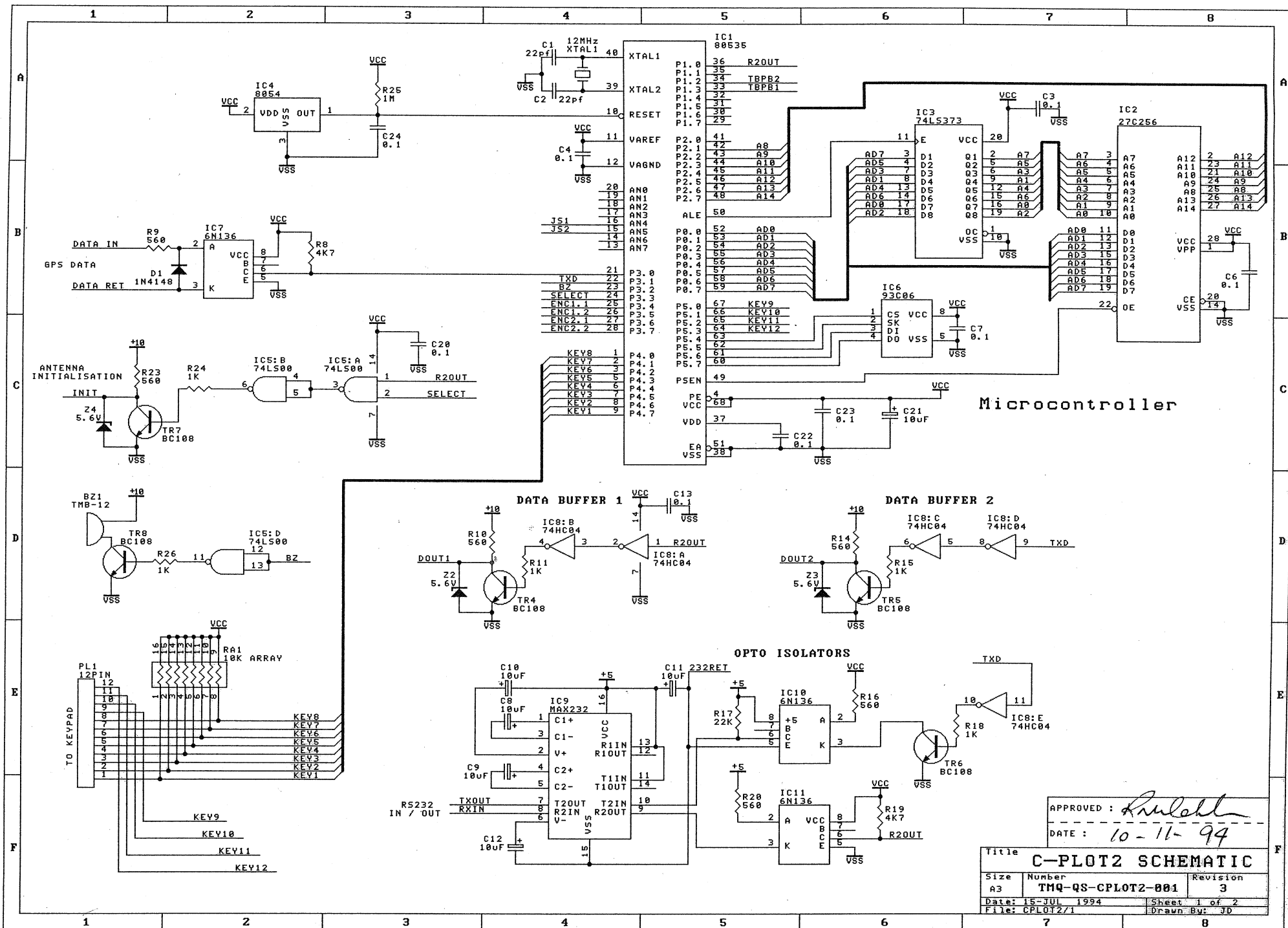

Microcontroller

APPROVED: *[Signature]*  
 DATE: 10-11-94

Title		
C-PLOT2 SCHEMATIC		
Size	Number	Revision
A3	TMQ-QS-CPLOT2-001	3
Date:	15-JUL 1994	Sheet 1 of 2
File:	CPLOT2/1	Drawn By: JD